

Notice de montage

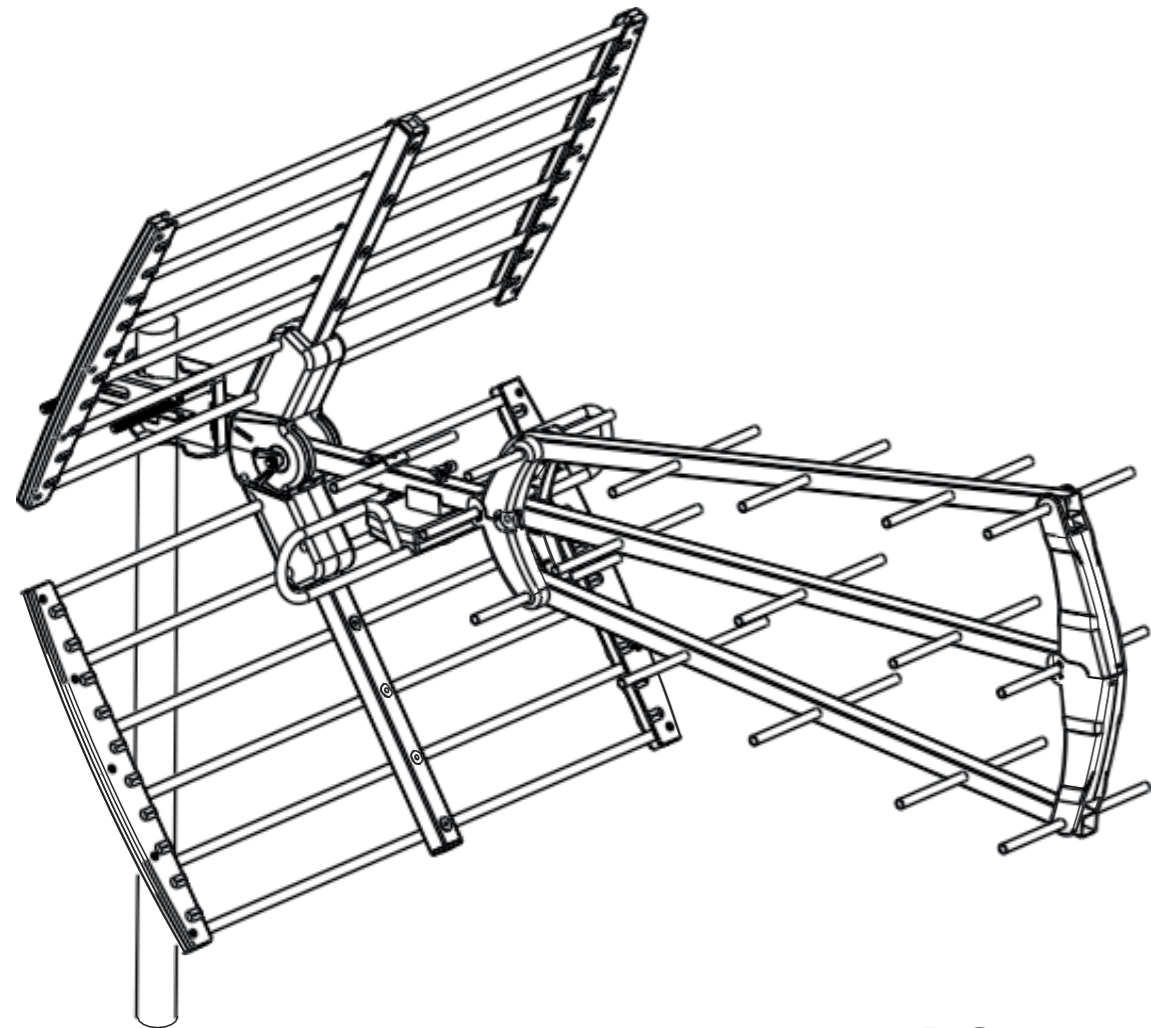

Référence TRI43

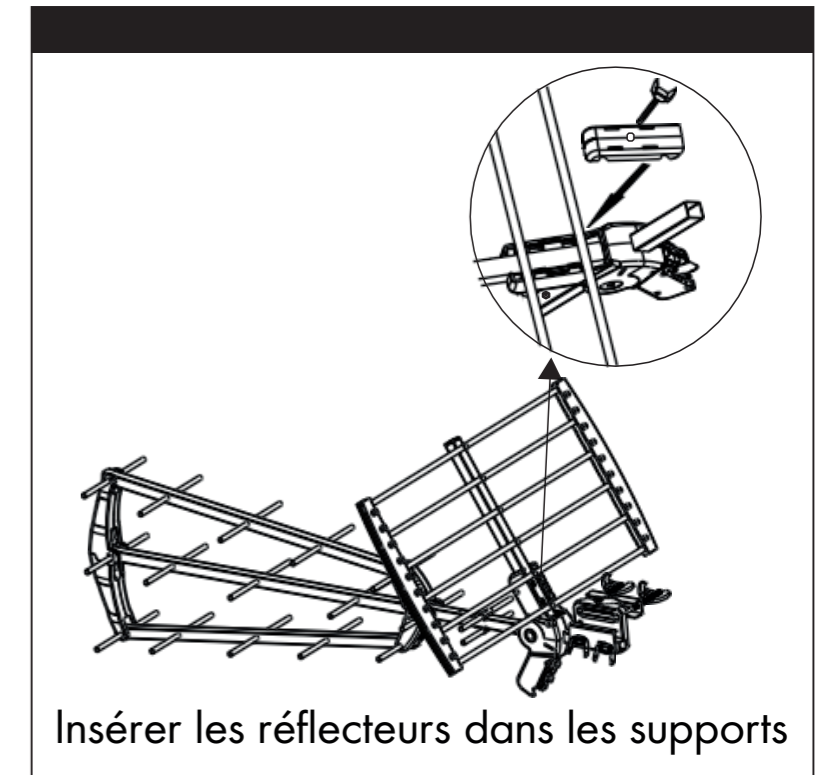
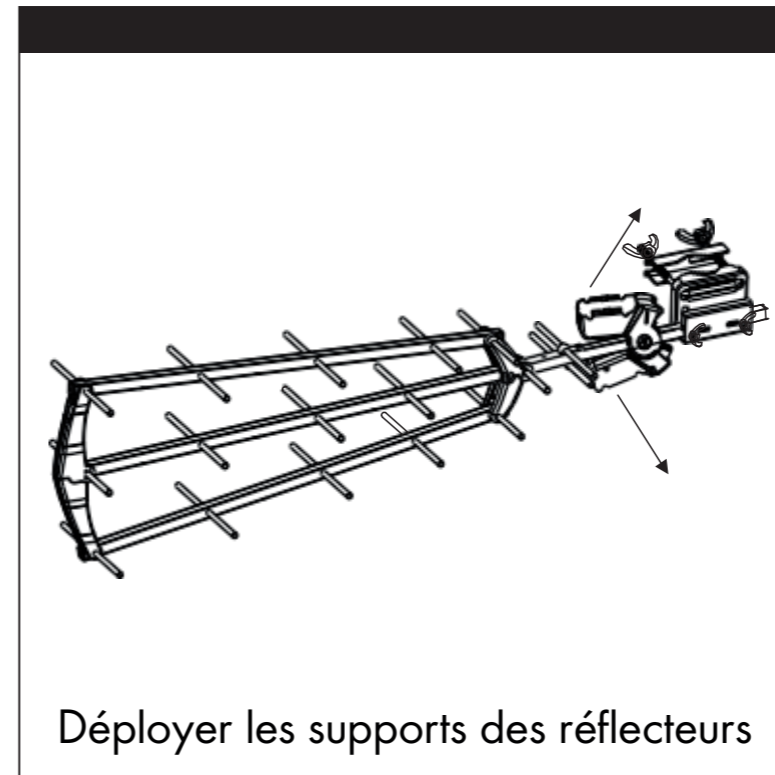

Fréquence	470 ~ 790 MHz
Canaux	21 ~ 60
Impédance	75 Ω
Gain	16 dB
Rapport avant-arrière	28 dB

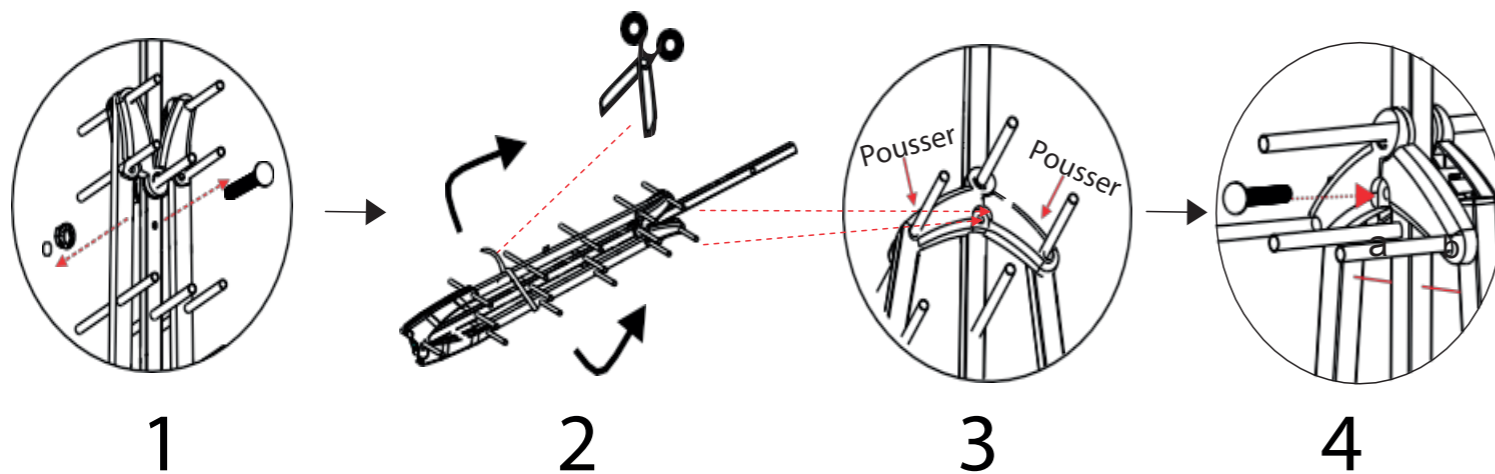

- ① Retirer la vis de blocage
- ② Couper les bandes de fixation
- ③ Positionner la charnière jusqu'à sa position finale
- ④ Insérer et serrer la vis de fixation

